

**Main Specifications**

▼ **CO**nnexion

Flanged ANSI 300, 150, JIS10K

▼ **P**ressure range

FC▼

0.3~10 kg

WCB▼

0.3~40 kg

SUS▼

0.3~40 kg

▼ **O**perating temperature

-5°C ~ 300°C

▼ **A**pplicable fluid

Steam / air / liquid that compatible with Stainless steel

**Full Bore Safety Valve**

**Model: SV-FB9.5**

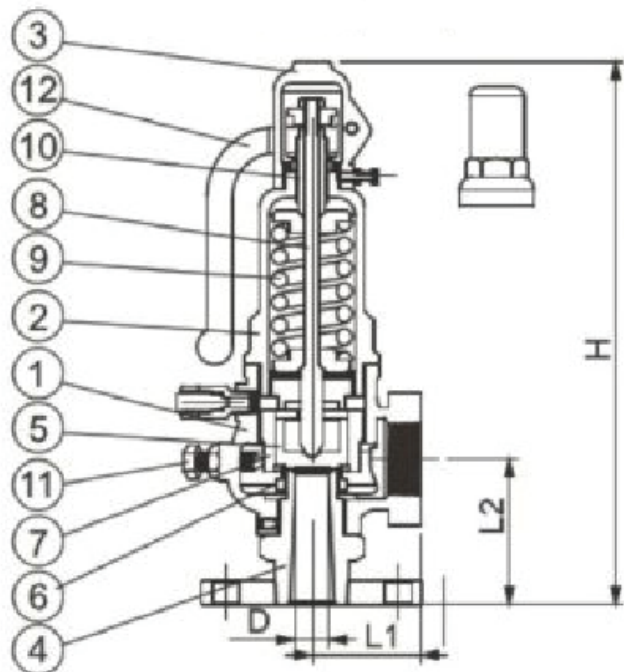

Due to the variety of customization, the picture is only for reference, please confirm the actual item with our sales.  
(If there is any change on specification, please take the latest version as standard.)

**Material Table**

No.	Name	Material		
1	Body	FC20	SCS13	WCB
2	Bonnet	FC20	SCS13	WCB
3	Cap	FC20	SCS13	WCB
4	Body Seat	SUS304	SUS304	SUS304
5	Valve Disc	SUS304	SUS304	SUS304
6	Lower Ring	SCS13	SUS304	SUS304
7	Upper Ring	BsBm	SUS304	SUS304
8	Stem	SUS304	SUS304	SUS304
9	Spring	SUP6	SUS304	SUS304
10	Adjusting Screw	SUS410	SUS304	SUS304
11	Orrt Screw	SUS310	SUS304	SUS304
12	Lever	WCB	SUS304	SUS304

**Dimension**

Seat Dia	Throat Dia		Lift	L1/L2		Height
	dt	n(mm)		L1	L2	
20*15*25	15	176.6	3.8	50	77	273
20*19*32	19	283.3	5	64	87	322
40*30*50	30	706.5	7.5	71	113	405
50*38*65	18	1133.5	9.5	85	125	450

Unit : mm