

Main Specifications

▼ Connection

Flanged ANSI 300, 150, JIS10K

▼ Pressure range

FC▼

0.3~10 kg

WCB▼

0.3~20 kg

SUS▼

0.3~20 kg

▼ Operating temperature

-5°C ~ 300°C

▼ Applicable fluid

Steam / air / liquid that compatible with Stainless steel

Low Lift Safety Valve

Model: SV-FB3.8

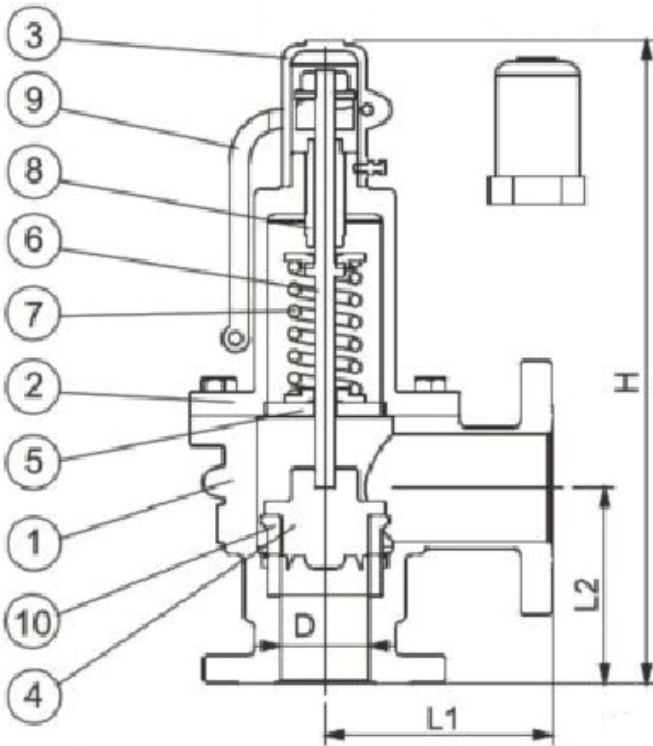

Due to the variety of customization, the picture is only for reference, please confirm the actual item with our sales. (If there is any change on specification, please take the latest version as standard.)

Material Table

No.	Name	Material			
1	Body	FC20	SS304	WCB	SCS14
2	Bonnet	FC20	SS304	WCB	SCS14
3	Cap	FC20	SS304	WCB	SCS14
4	Disc	SS304	SS304	SS304	SCS14
5	Stem guide	FC20	SS304	SS304	SS316
6	Stem	SS410	SS304	SS304	SS316
7	Spring	SWPA	SS304	SWPA	SS316
8	Adjusting Screw	SS410	SS304	SS410	SS316
9	Handle	WCB	SS304	WCB	SS316
10	Seat	SS304	SS304	SS304	SCS14

Dimension

Outlet diameter	Inlet diameter	Throat Dia	Lift	L1/L2		Height
d	D	n(mm)	l	L1	L2	H
25	25	54.9	0.7	89	74	300
32	32	80.3	0.8	105	110	390
40	40	125.6	1	105	110	390
50	50	204.1	1.3	110	110	399
65	65	346.9	1.7	117	116	460
75	75	447.4	2	147	146	517
100	100	788	2.5	189	180	624
125	125	1256	3.2	190	183	720
150	150	1789.8	3.8	210	210	800

Unit : mm