

## Main Specifications

## ▼ Type

A60V / A60VL / A60P / A60PL  
For detail please refer to technical specification table

## ▼ Size

1.2" (30mm)

## ▼ Pressure connection

Material: SS 304L (standard) / SS 316L (option)

Laser welding

Thread spec.: 1/8"

Other available upon request

## ▼ Pressure range

Positive pressure ▼

0 to 10bar

Negative pressure ▼

-101 to 0kPa

## ▼ Applicable fluid

Pure, non-corrosive gases

## ▼ Ambient temperature

-40°C to +60°C

## ▼ Fluid temperature

-10°C to 60°C

## ▼ Ambient humidity

85% R.H.

## ▼ Atmospheric pressure

860...1060 mbar

## ▼ Temperature error

Standard temp.: 22°C

max. error: ±0.5% F.S

(0~50°C)

## ▼ Protection level

IP65(\*1)

## ▼ Test data

Vibration test: 10 to 55 Hz, 10g sinusoidal in 3 axes for 2 hours

Humidity test: 250 hours (40°C and 90% to 95% R.H)

Impact test: 100m/s<sup>2</sup> (10g)

sinusoidal in 3 axes for 3 times

## Other Specifications

## ▼ Ring

ABS, Screw fixed

## ▼ Back housing

ABS

## ▼ Screen display

3.5-digit LCD display

Yellow backlight

## ▼ Refresh rate

2 times/sec

## ▼ Screen size

25 x 15 mm

## ▼ Pressure unit

Positive pressure ▼

psi, bar, kg/cm<sup>2</sup>, MPa

Negative pressure ▼

psi, bar, mmHg, kPa

## ▼ Resolution

0.001

## ▼ Measuring elements

High-tech silicon chip

## ▼ Accuracy

2% (0~50°C)

## ▼ Max. operating pressure

Positive pressure ▼

15bar

Negative pressure ▼

300kPa

## ▼ Compensated temperature

0°C to 50°C

## ▼ Power supply

CR 2032 lithium battery

Auto power saving mode after idle for 60secs

## ▼ Weight

40g

## Mini Air Digital Pressure Gauge

## Model: DPG-A60 Series

## Introduction

The 1" economic digital pressure gauge is suitable for pressure measurement in limit space.



Due to the variety of customization, the picture is only for reference, please confirm the actual item with our sales. (If there is any change on specification, please take the latest version as standard.)

## Features

- OEM service
- Connection part laser welding
- Auto power off design to conserve energy
- Instant measure pressure once power on
- Protection level IP65(\*1)

\*1 To install Air-tube to reach to IP65 class.

### Technical specification table

Pressure type	Vacuum pressure		Positive pressure	
	A60V	A60VL	A60P	A60PL
Type				
Rated pressure range	-101...0 kPa		0...10 bar	
Display pressure range	-101...10 kPa		-1...10 bar	
Max. operating pressure	300 kPa		15 bar	
Backlight	NO	YES	NO	YES
Battery life	3 years (5 times/day)	1 year (5 times/day)	3 years (5 times/day)	1 year (5 times/day)
Pressure unit	psi, bar, mmHg, kPa		psi, bar, kg/cm <sup>2</sup> , MPa	
Repeatability	1% F.S.		0.2% F.S.	
Pressure connection	Standard 1/8" PT, other available upon request (fixed thread size)			

### Support rack Installation

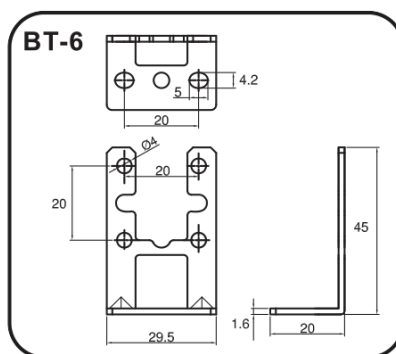
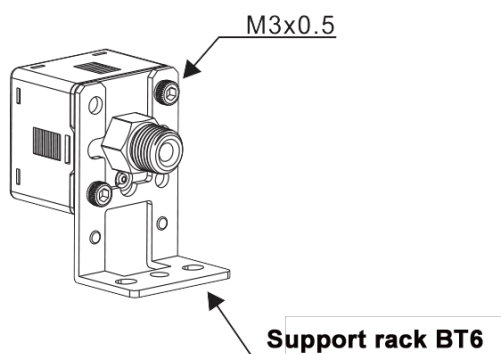
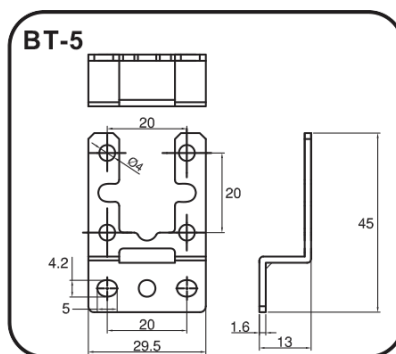
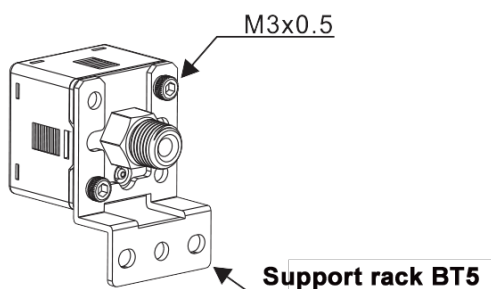

**Panel installation**

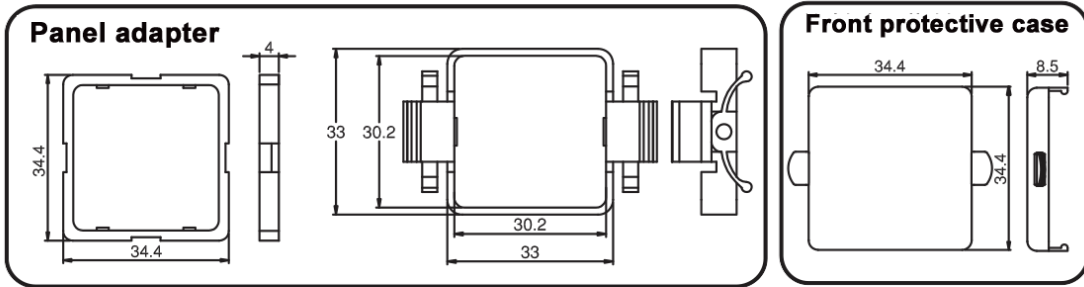
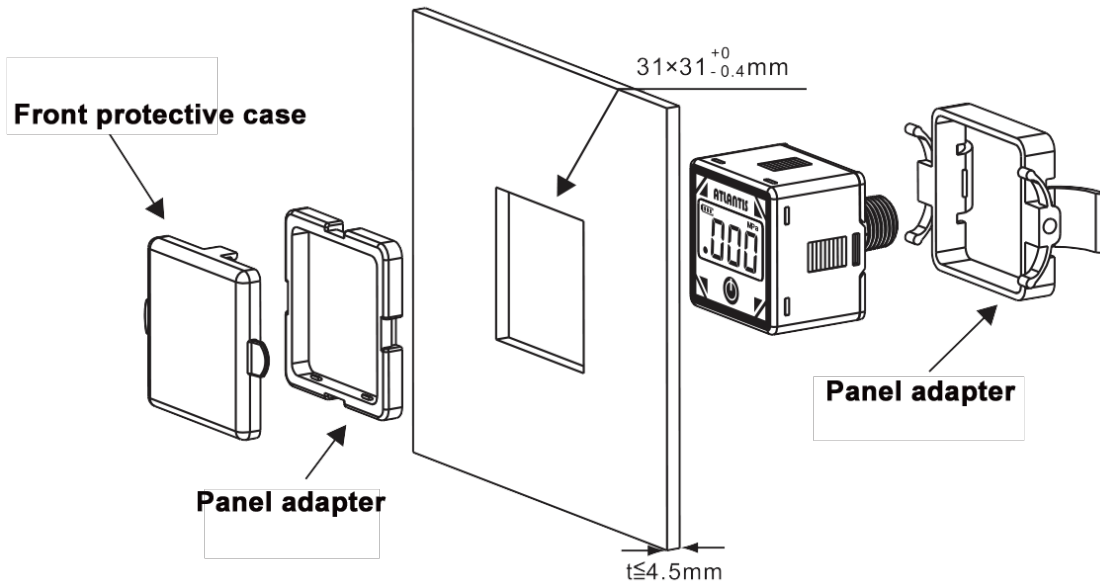

Unit:mm

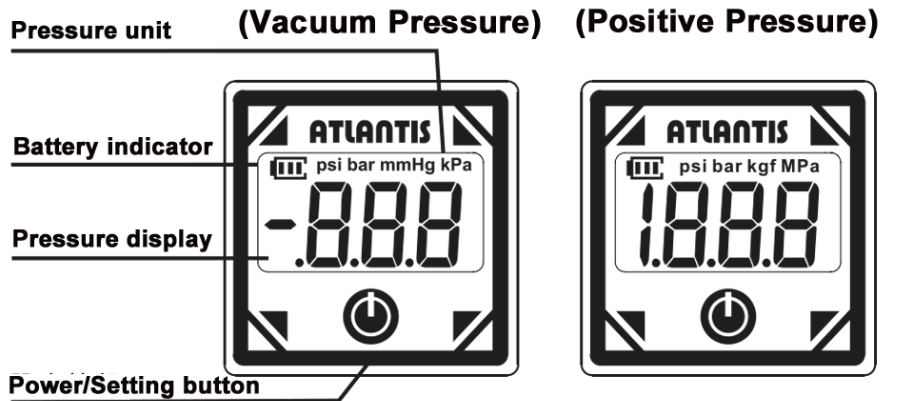
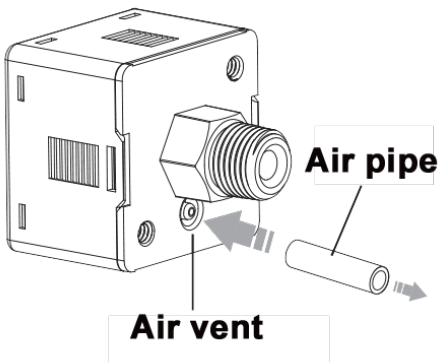

## How to order

DPG-A60		Mini air digital pressure gauge		
Code		Type		
V		A60V (negative pressure, no backlight)		
VL		A60VL (negative pressure, with backlight)		
P		A60P (positive pressure, no backlight)		
PL		A60PL (positive pressure, with backlight)		
Code		Pressure connection		
1P		1/8" PT		
O		Others (please specify)		
Code		Connection material		
304L		SS304L		
316L		SS316L		
O		Others (please specify)		
Code		Other requests		
/A		Third party notarized document		
/B		Inspection report (issued by Re-Atlantis)		
/C		Tag		
/D		Customized dial face (brand, color, etc.)		
/E		Thread adaptor: to adapt the other kind of threads		
/F		Panel adapter		
/G		Protective case		
/H		Support rack BT5		
/I		Support rack BT6		
DPG-A60	PL	1P	304L	Order example: DPG-A60PL-1P-304L+/H